

228T



Owner's Manual Supplement

www.seafoxboats.com

SEA FOX BOAT'S DISCLAIMER

The following Owner's Manual is provided for information and educational purposes only and is not intended to offer or provide legal advice or create a contractual relationship between Sea Fox Boat Company and the owner of any Sea Fox brand vessel. Please beware that as a vessel owner you have non-delegable responsibilities regarding the safety, maintenance, fitness, and operation of your vessel and the extent of such responsibilities is ultimately determined by Federal law and regulations, the general maritime law of the United States, the laws and regulations of the states and territories of the United States, or the laws and regulations of the country where you operate your vessel. To fully understand your responsibilities as a vessel owner, and before operating or letting any third-party operate your vessel, we recommend that you consult the services of a qualified lawyer in admiralty and maritime law.

TABLE OF CONTENTS

Introduction	3	Electrical Schematics	14
Specifications	3	Main Harness	14
Designated Occupant Seating	4	Switch Panel	15
Safety Decals	5	Deck Harness	16
Plumbing Schematics	7	Ultima Top Harness	17
Fuel System	7	Mood Lights	18
Bilge System	8	Underwater Lights Harness	19
Fresh Water System	9	Electric Head Harness	20
Raw Water System	10	Battery Wiring	21
Drains	11		
Livewell System	12		
Electric Head	13		

This Page Intentionally Left Blank

INTRODUCTION

Congratulations and Welcome Aboard! With so many boat brands to choose from, we want to congratulate you on your decision to choose Sea Fox Boats. For more than 24 years, Sea Fox offers the finest hand-crafted saltwater boats carefully balanced with the build-quality, features, styling and performance for the fairest price. Our passion for boating is evident in every model we make and we appreciate that you've noticed the Sea Fox difference.

We share your love for the moments spent on the water with friends and family, which is why every Sea Fox boat offers a unique blend of fishing/family options, technologies and innovative features. Your choice of a Sea Fox affirms that you have performed your research and compared the value of your model with the competition.

Whether you are new to the boating lifestyle or an old salt, we ask that **you and all other operators** read the owner's manual, this supplement, and all other literature provided with the boat **before** operating the boat or any equipment. We also recommend that all operators enroll in a boating safety course available online - see References and Contact Information in this section for education resources online.

This supplement contains model-specific information not included with the owner's manual. This manual is not intended to be a replacement for specific product literature provided by engine, accessory or other major equipment manufacturers, but rather to supplement that information.

Because of our philosophy of continuous product improvement, this manual serves as a general guide only, so the specifications and illustrations used may not match the equipment on your boat and are intended only as general reference views.

We welcome you to the Sea Fox family and wish you many years of boating enjoyment!

SPECIFICATIONS

Max. Weight Capacity	2,200 lbs (998 kg)
Persons	8
Persons Weight	1,200 lbs (544 kg)
Max. HP	250 hp (186 kw)
L.O.A.	22' 4" (6.81 m)
Beam	8' 6" (2.59 m)
Draft	16 in. (0.41 m)
Height, Keel to Top (Light Folded)	115 in. (2.92 m)
Bridge Clearance Hard Top	99 in. (2.51 m)
Max. Weight Boat (w/ Fluids, Largest HP)	5,226 lbs (2,371 kg)
Fuel Tank Capacity	106 gal (401 L)
Freshwater Tank Capacity	12 gal (45 L)
Holding Tank Capacity	6 gal (23 L)

DESIGNATED OCCUPANT SEATING

Be sure all passengers are properly seated in designated seating positions and not riding on the bow, bow pulpit, deck, gunwale or rear sun deck while underway. Passengers must use hand-holds and use caution when riding in the bow. Move to the aft passenger seats during rough water operation or if visibility is restricted.

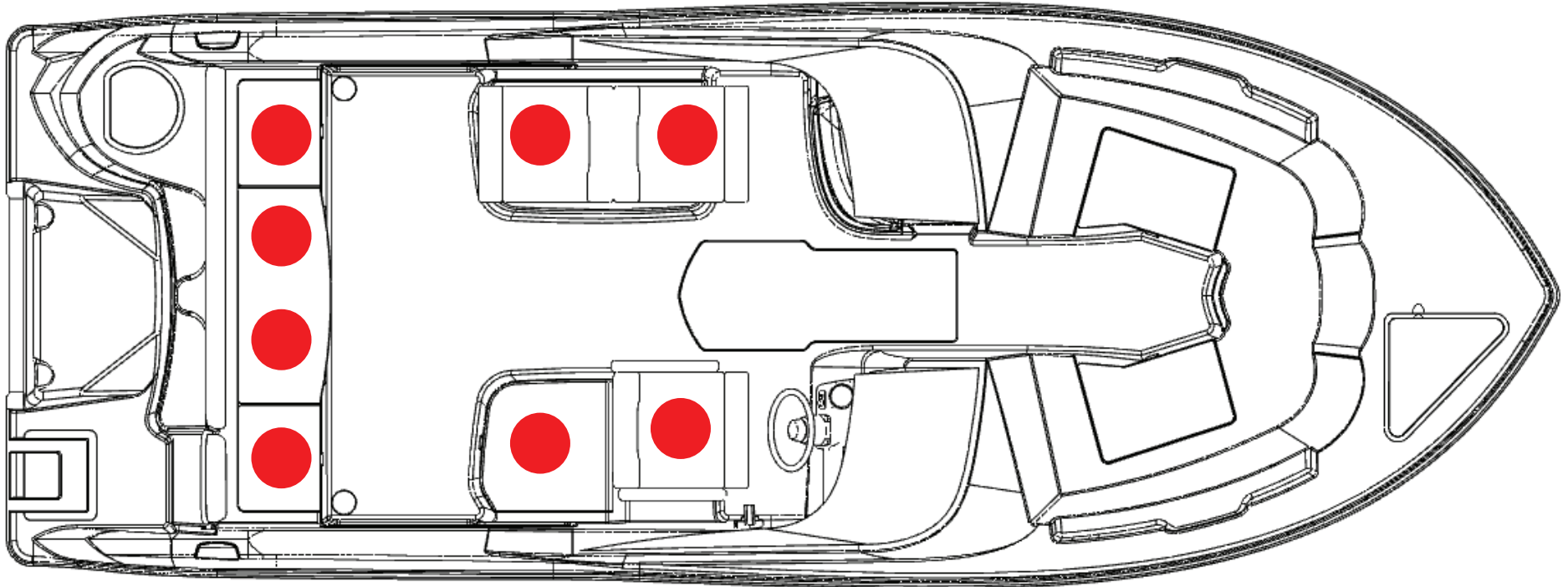

● = Seat position

SFOX-0022

SAFETY DECALS

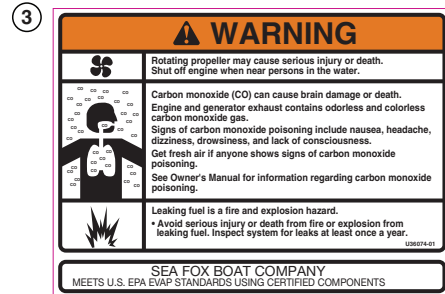
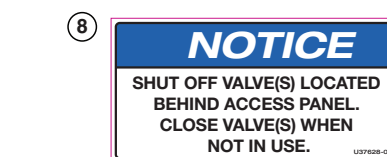
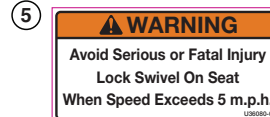
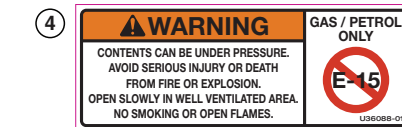
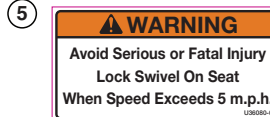
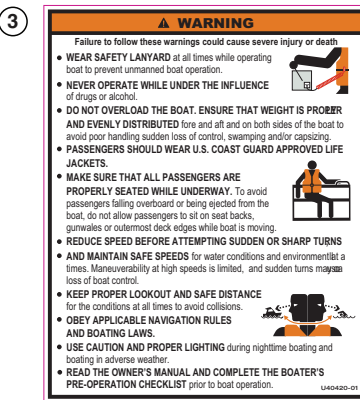
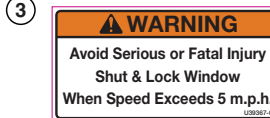
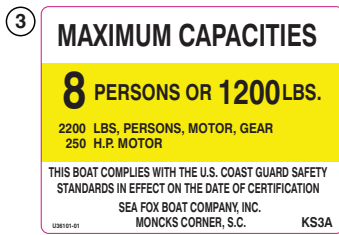
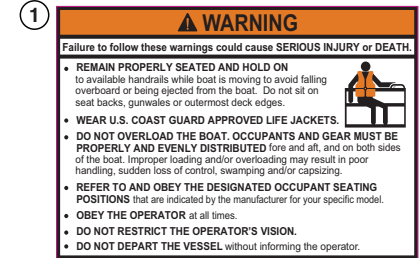
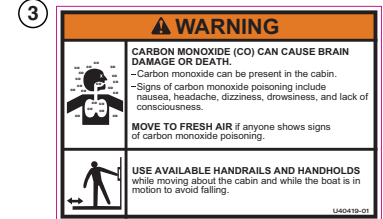
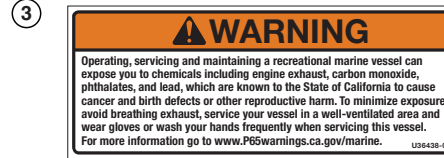

- 1= COCKPIT FRONT
- 2= HEAD COMPARTMENT
- 3= HELM
- 4= FUEL FILL
- 5= COCKPIT MID SHIP
- 6= COCKPIT AFT
- 7= TRANSOM GATE
- 8= TRANSOM

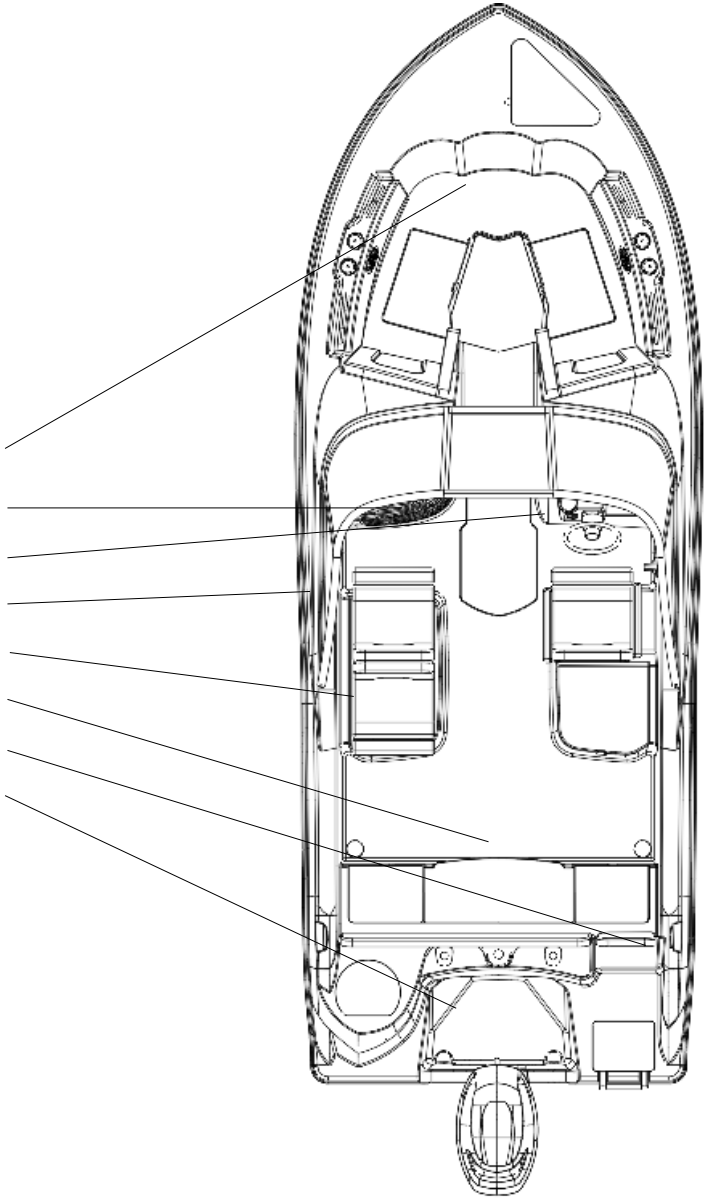

PLUMBING SCHEMATICS

FUEL SYSTEM

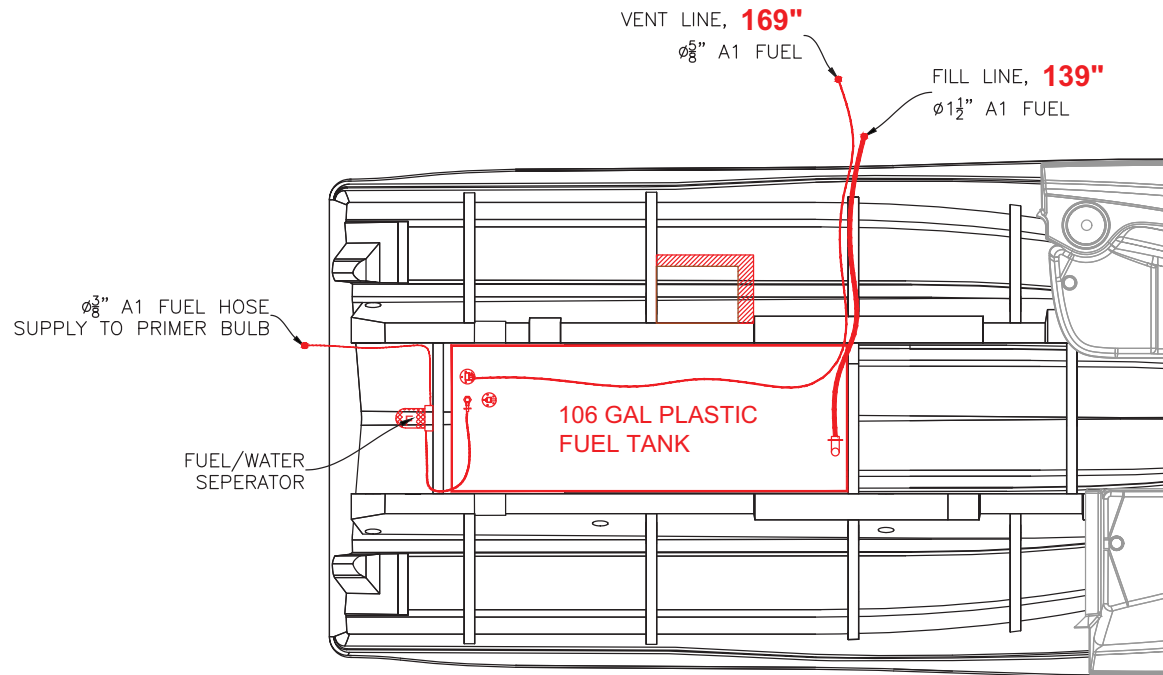
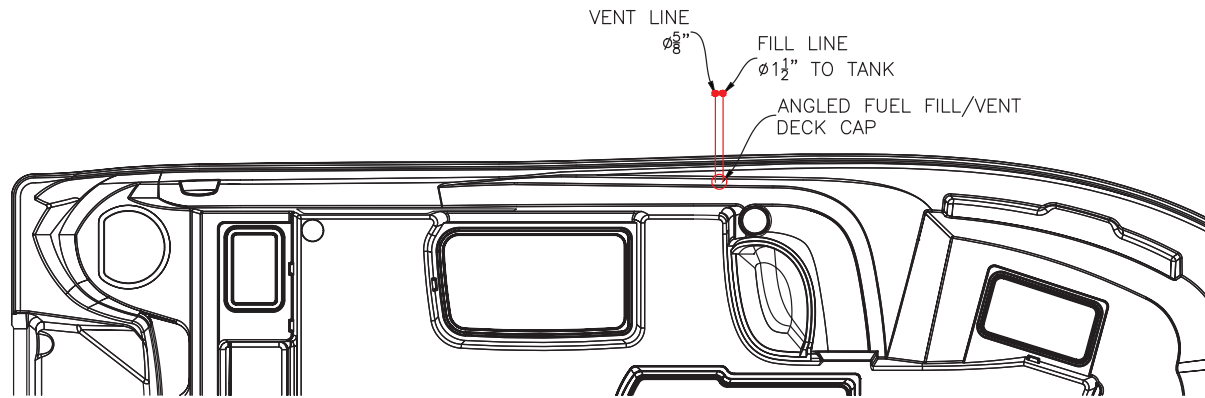

BILGE SYSTEM

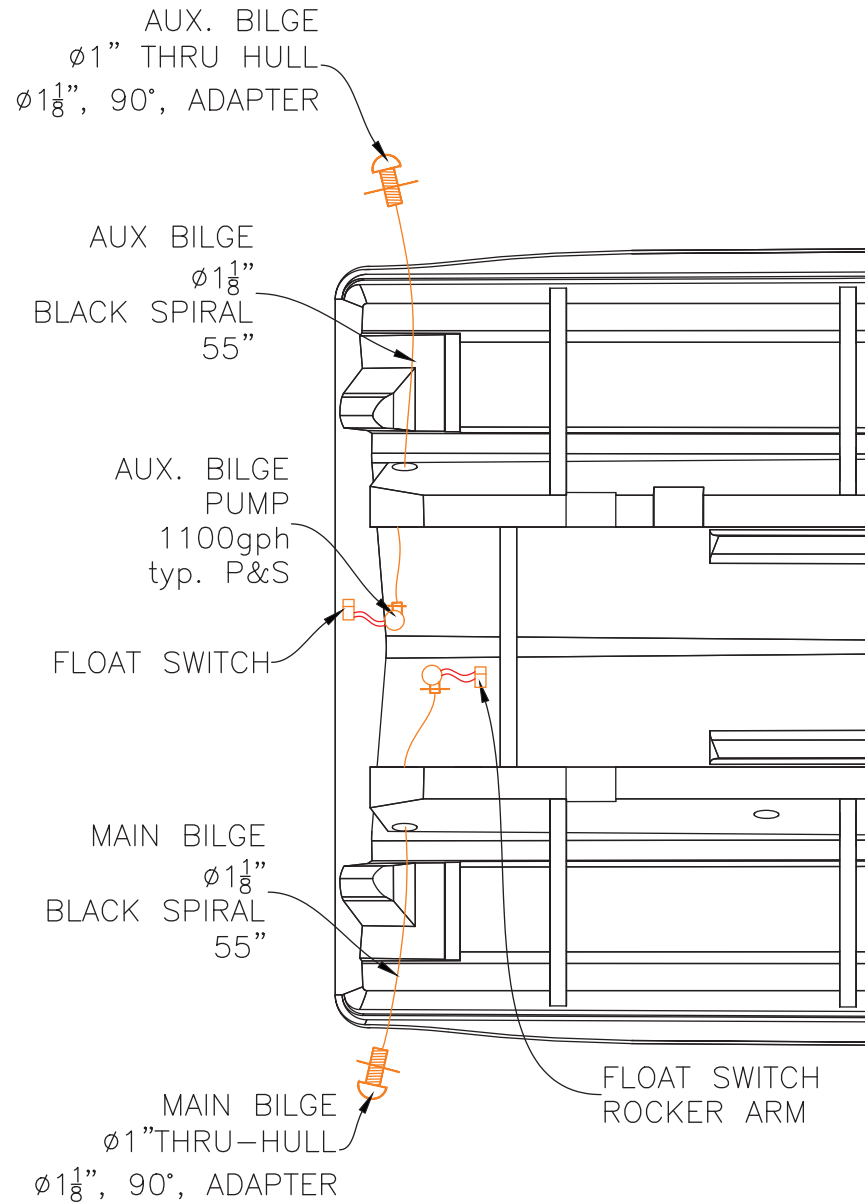

FRESH WATER SYSTEM

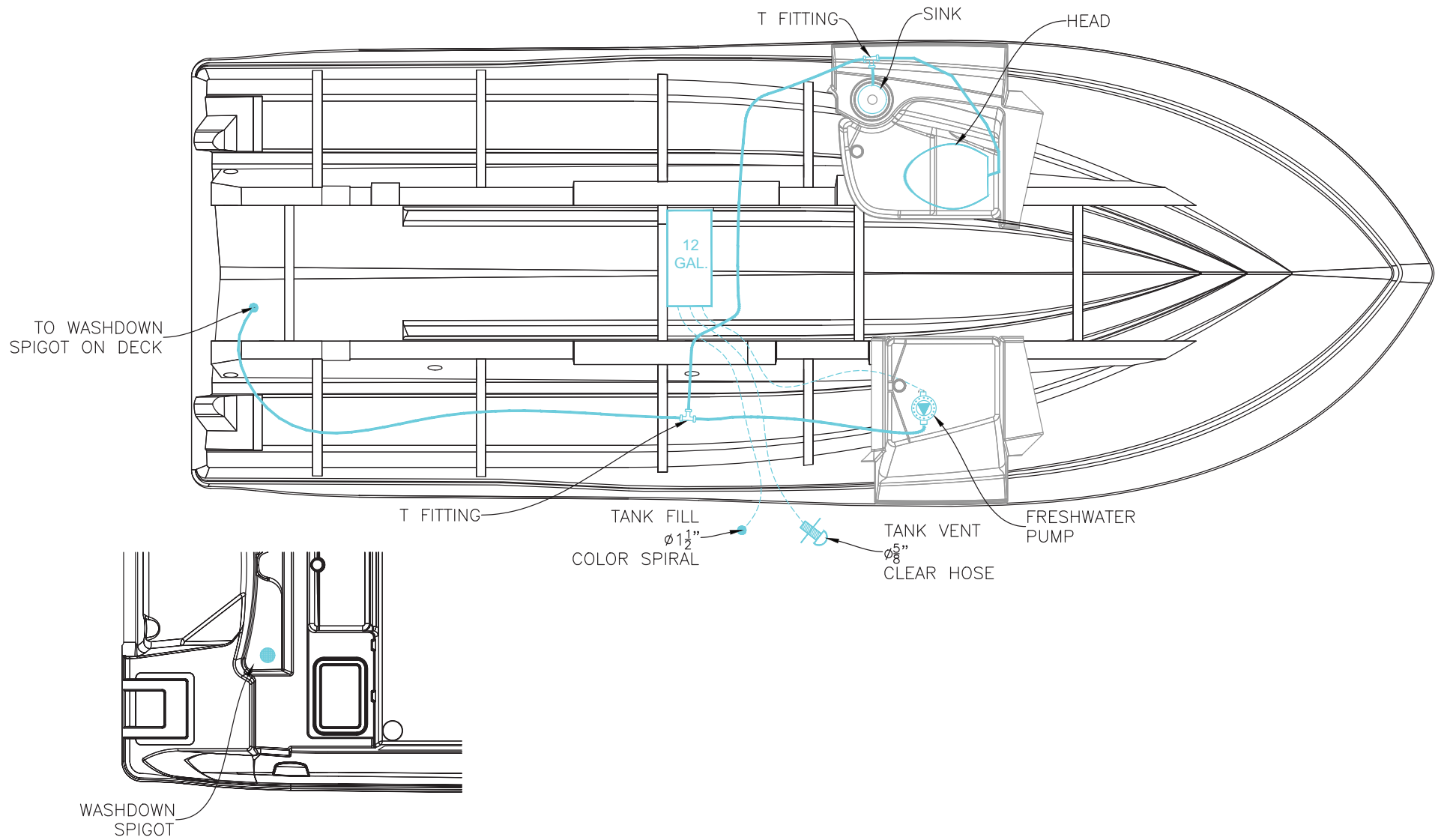

RAW WATER SYSTEM

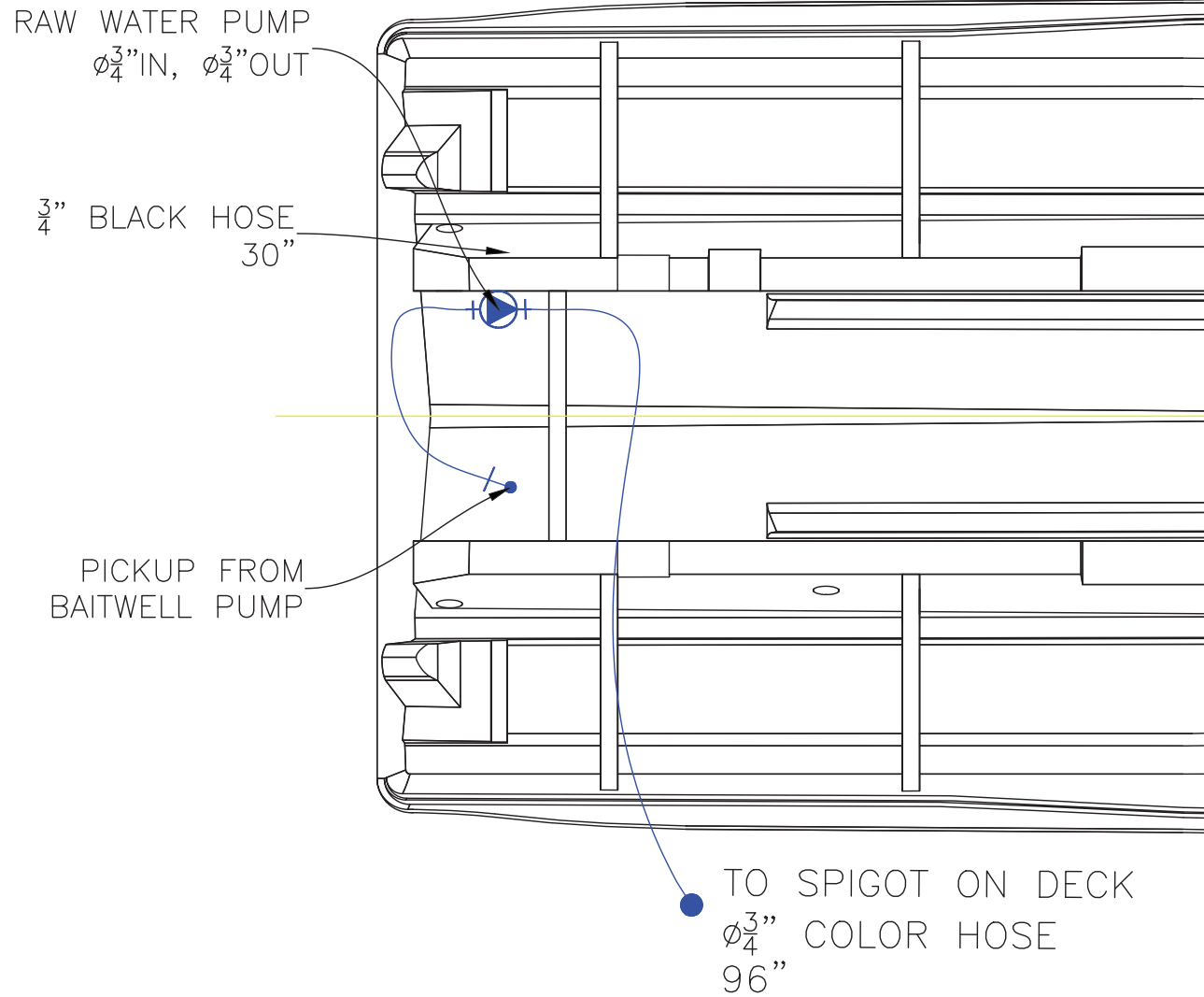

DRAINS

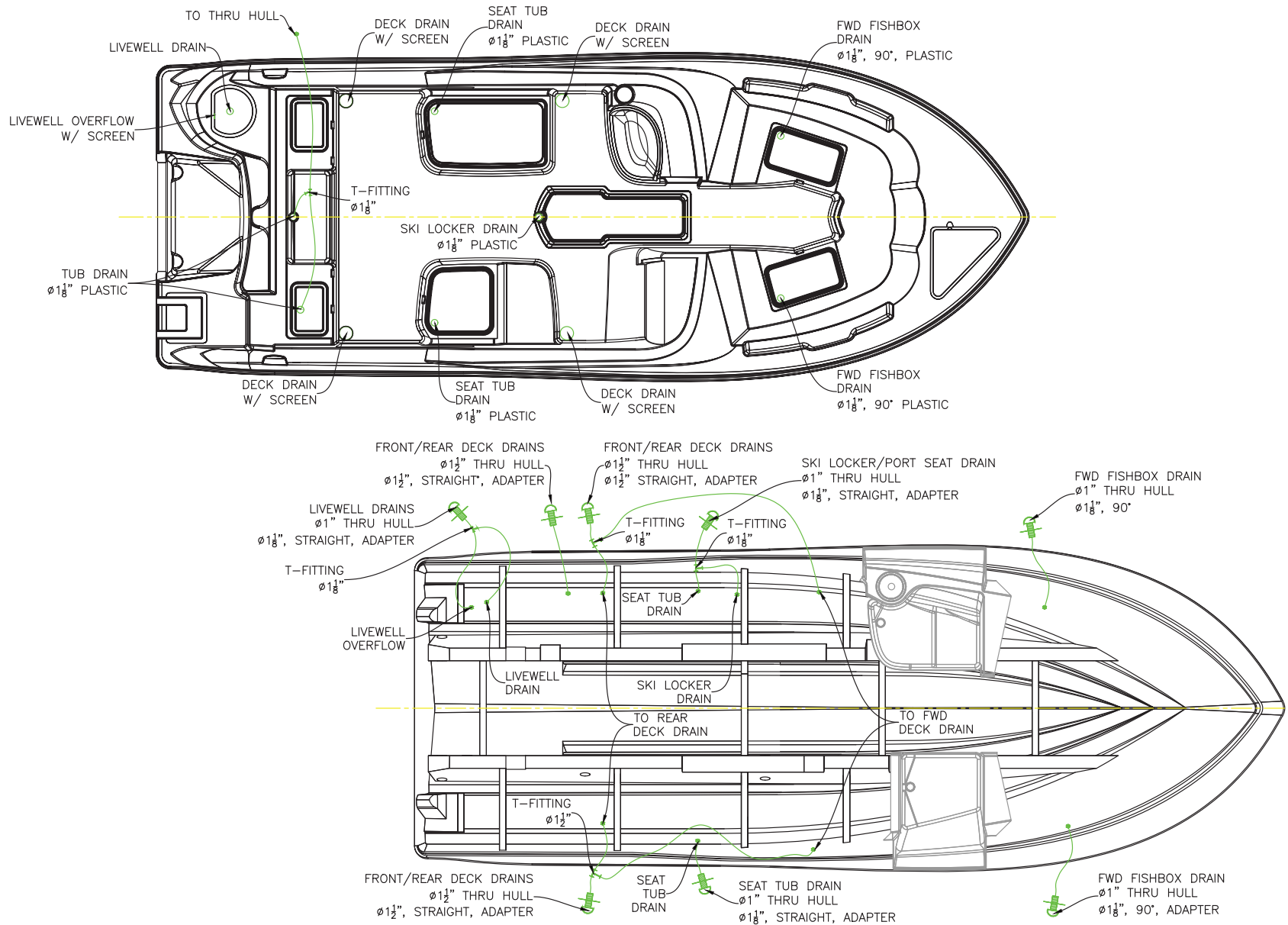

LIVEWELL SYSTEM

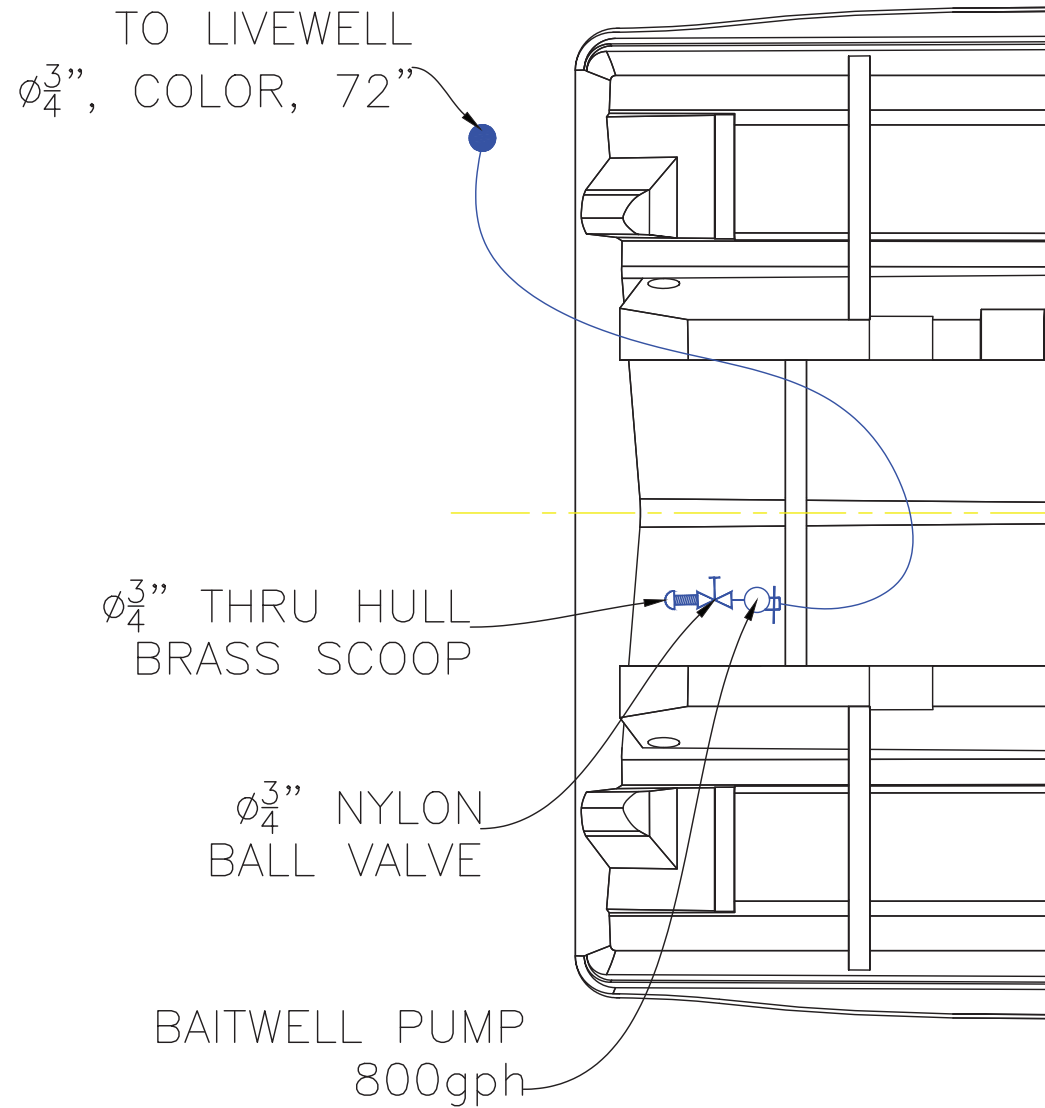

ELECTRIC HEAD SYSTEM

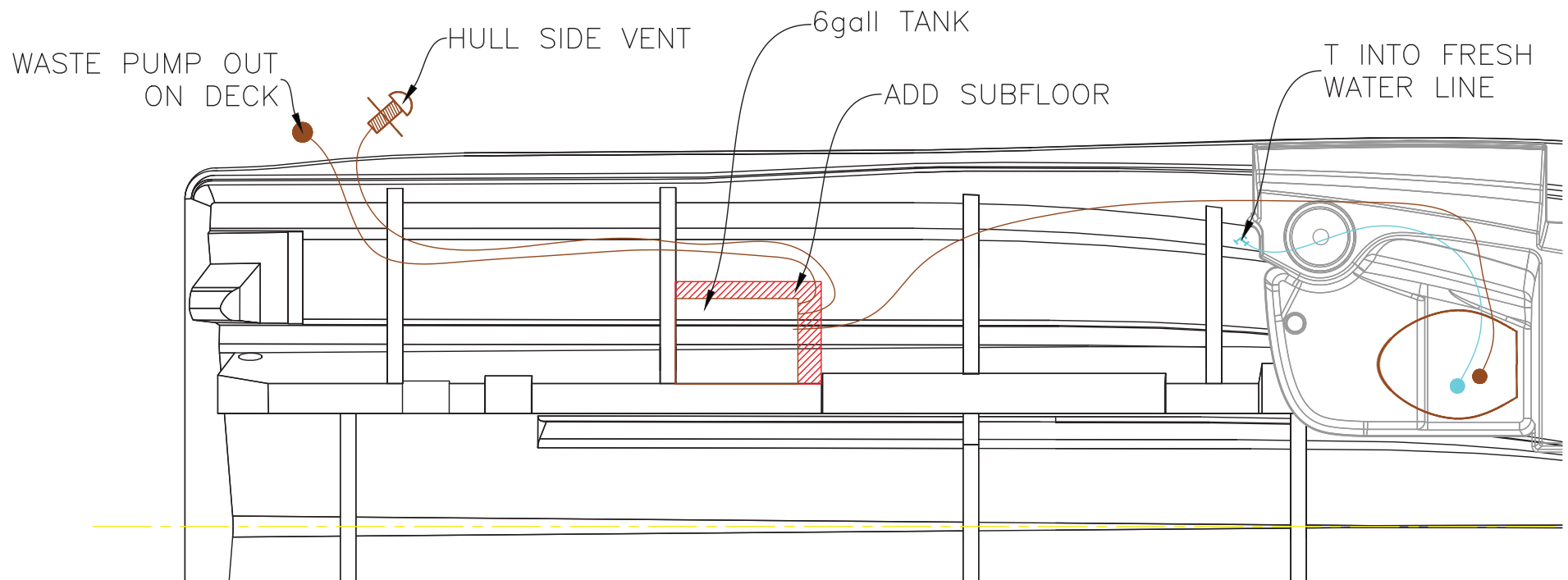

ELECTRICAL SCHEMATICS

MAIN HARNESS

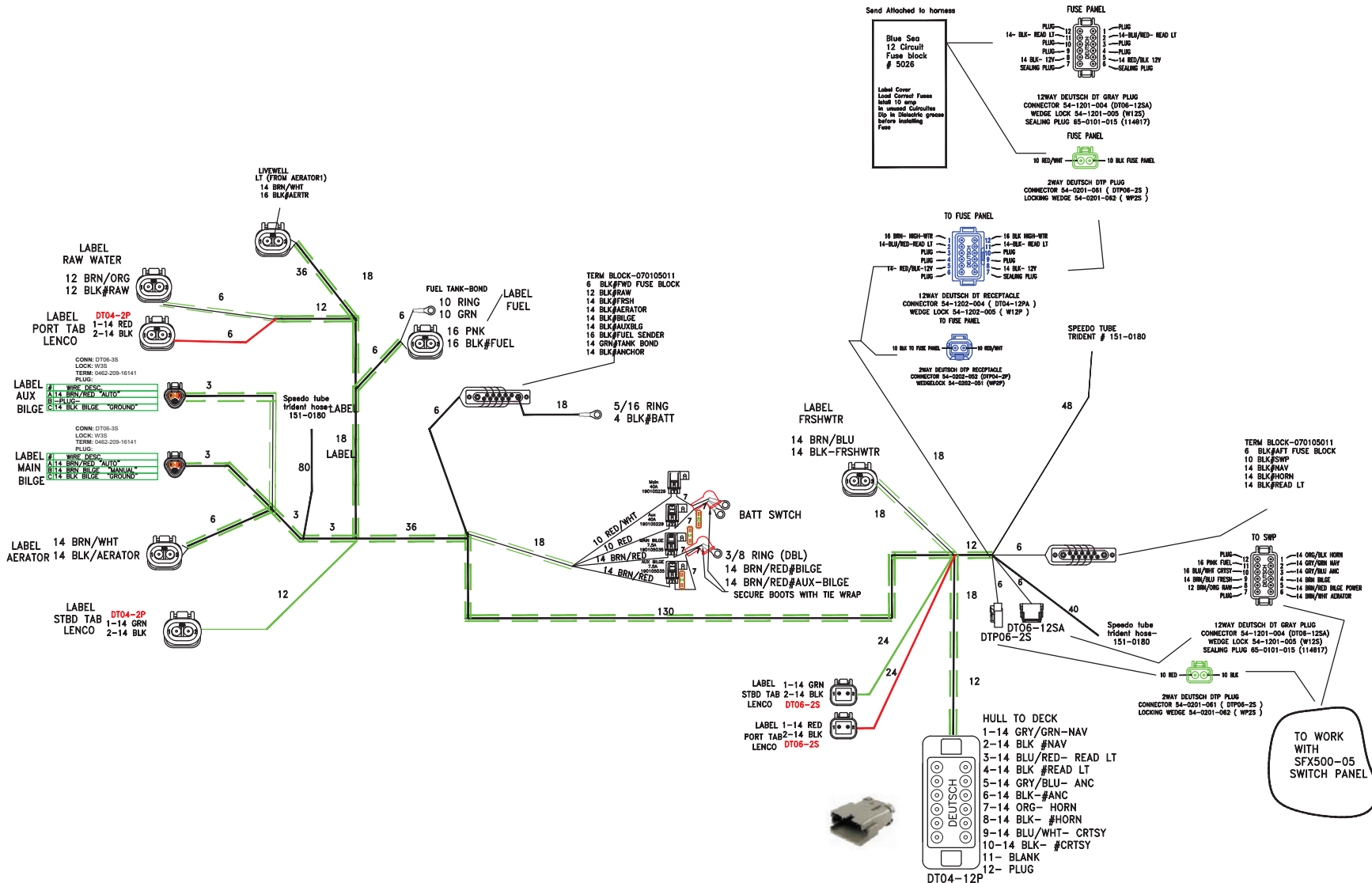

DECK HARNESS

228TR DECK HARNESS

- = NON-INS #10 EYELET CONNECTOR W/ DBL-WALL SHRINK
- = NON-INS 6.3MM FEM. QUICK CONNECTOR W/ DBL-WALL SHRINK
- = NON-INS 4.8MM FEM. QUICK CONNECTOR W/ DBL-WALL SHRINK
- = NON-INS BUTT CONNECTOR W/ DBL-WALL SHRINK
- = NON-INS 4MM MALE BULLET CONNECTOR W/ DBL-WALL SHRINK
- = NON-INS 4MM FEMALE BULLET CONNECTOR W/ DBL-WALL SHRINK

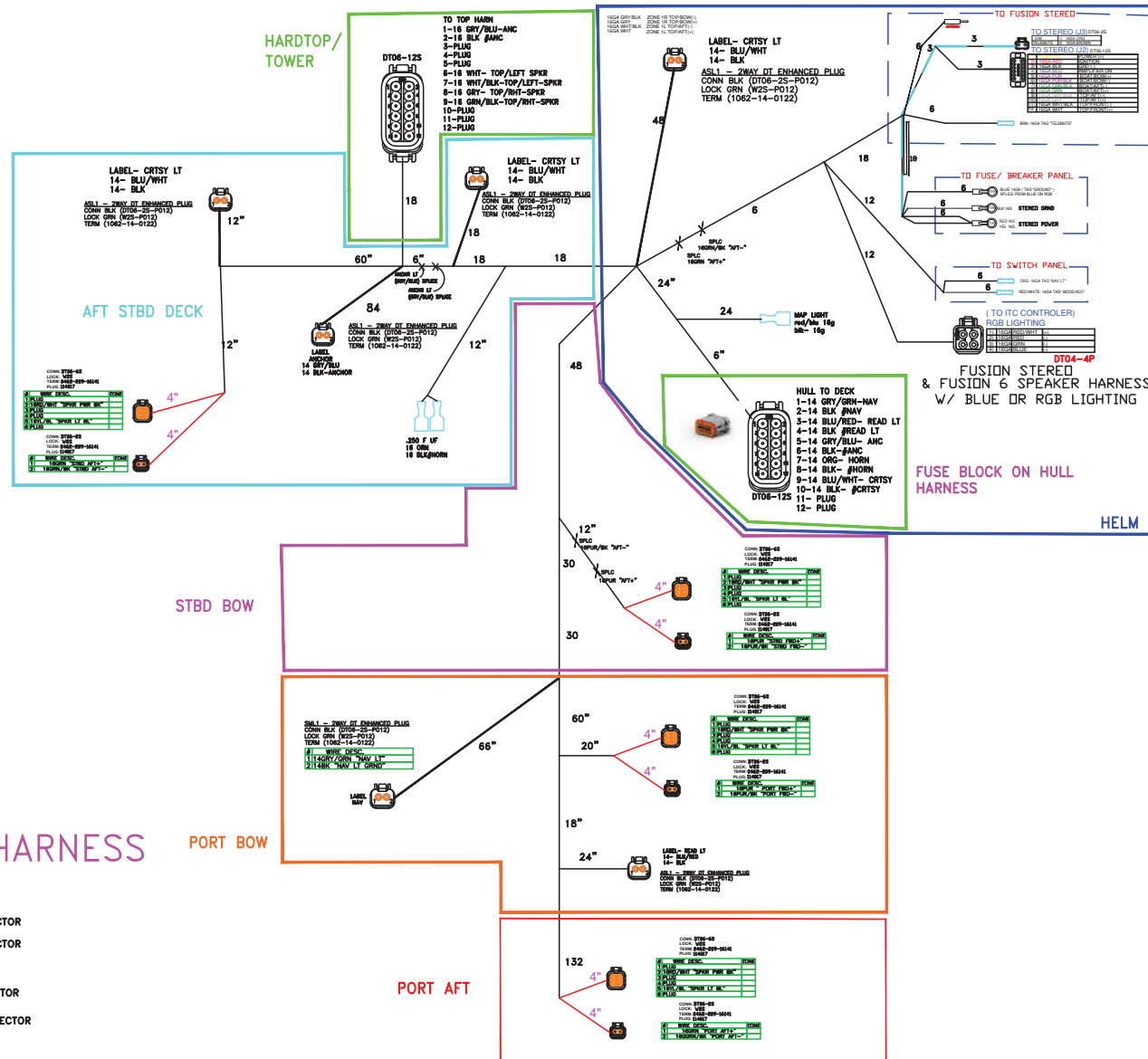

ULTIMA TOP HARNESS

HARD TOP OPTION

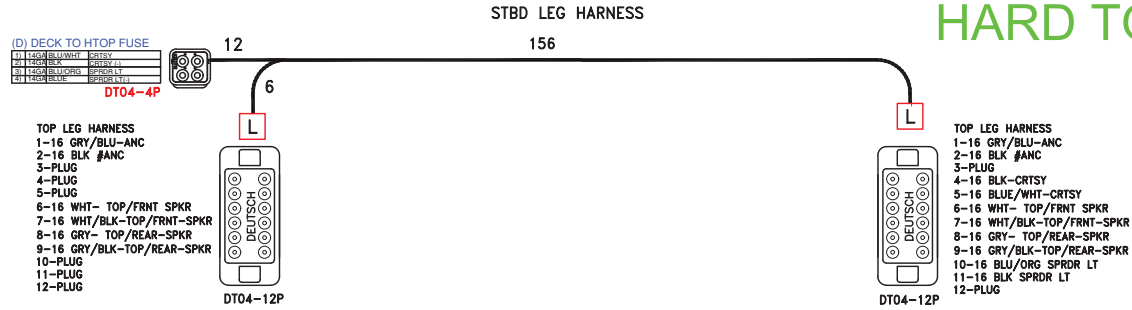

HARD TOP HARNESS

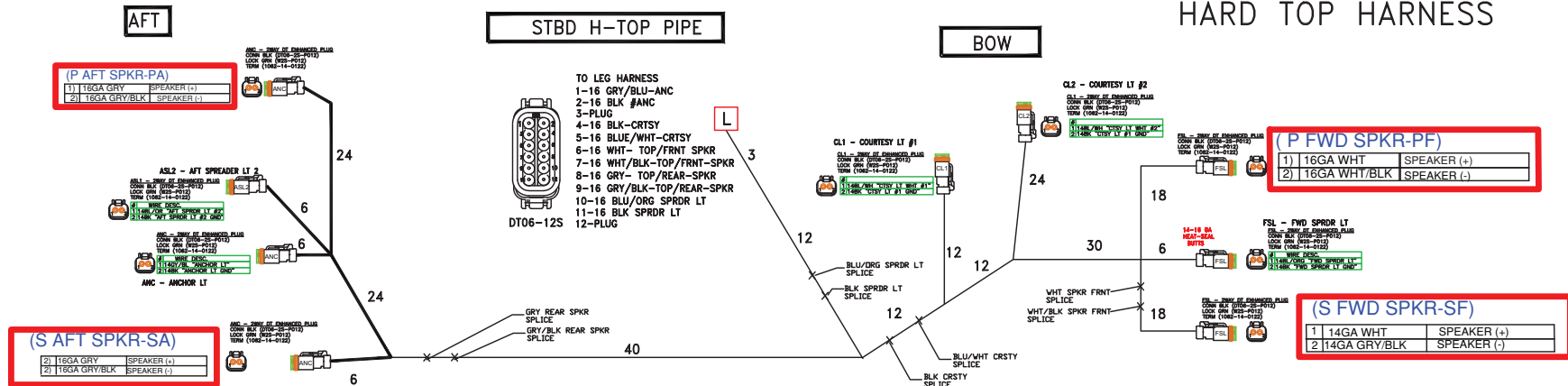

Panel kit

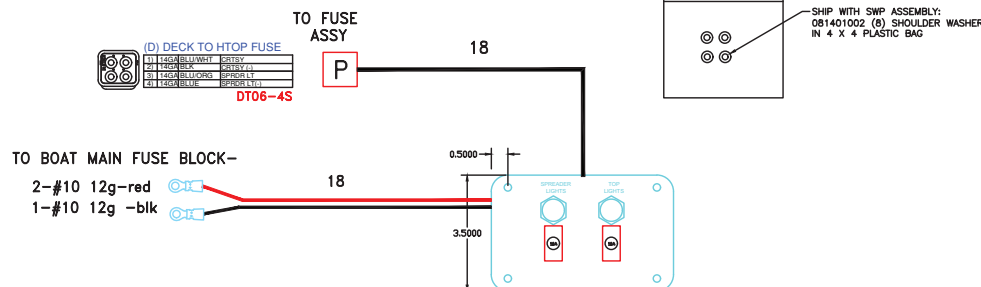

UNDERWATER LIGHTS HARNESS

UNDER WATER LIGHT OPTION

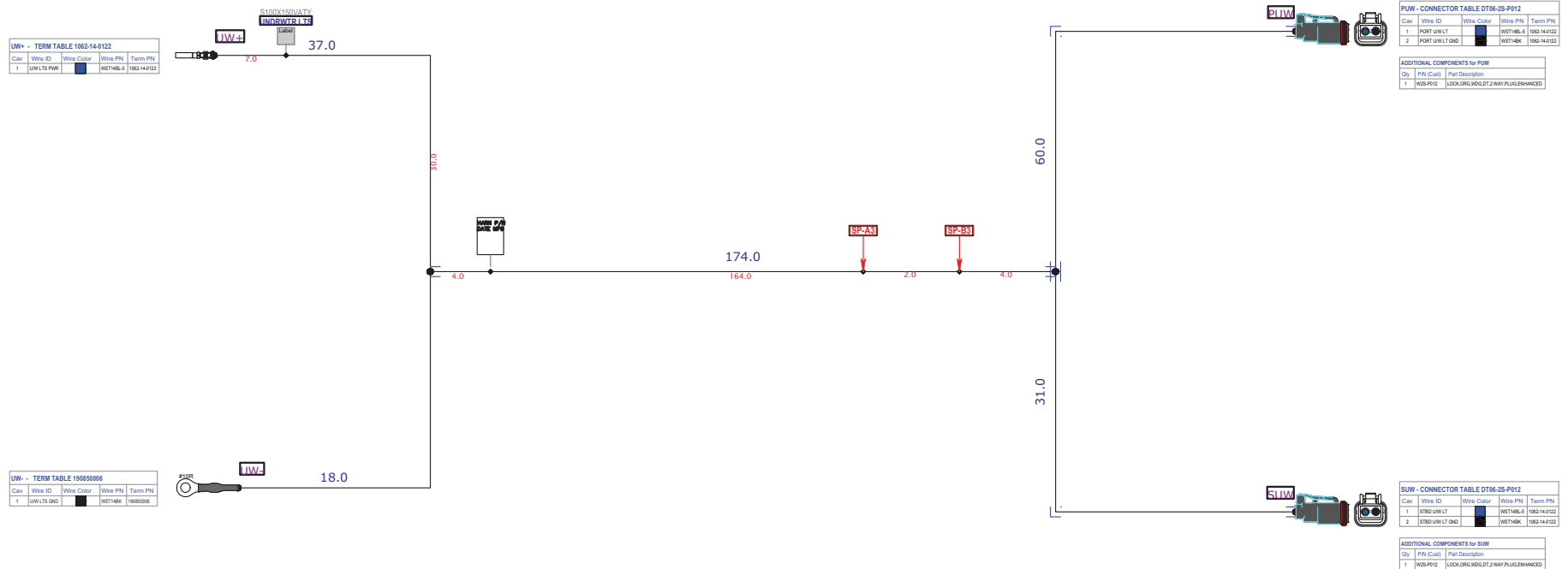

TOILET OPTION

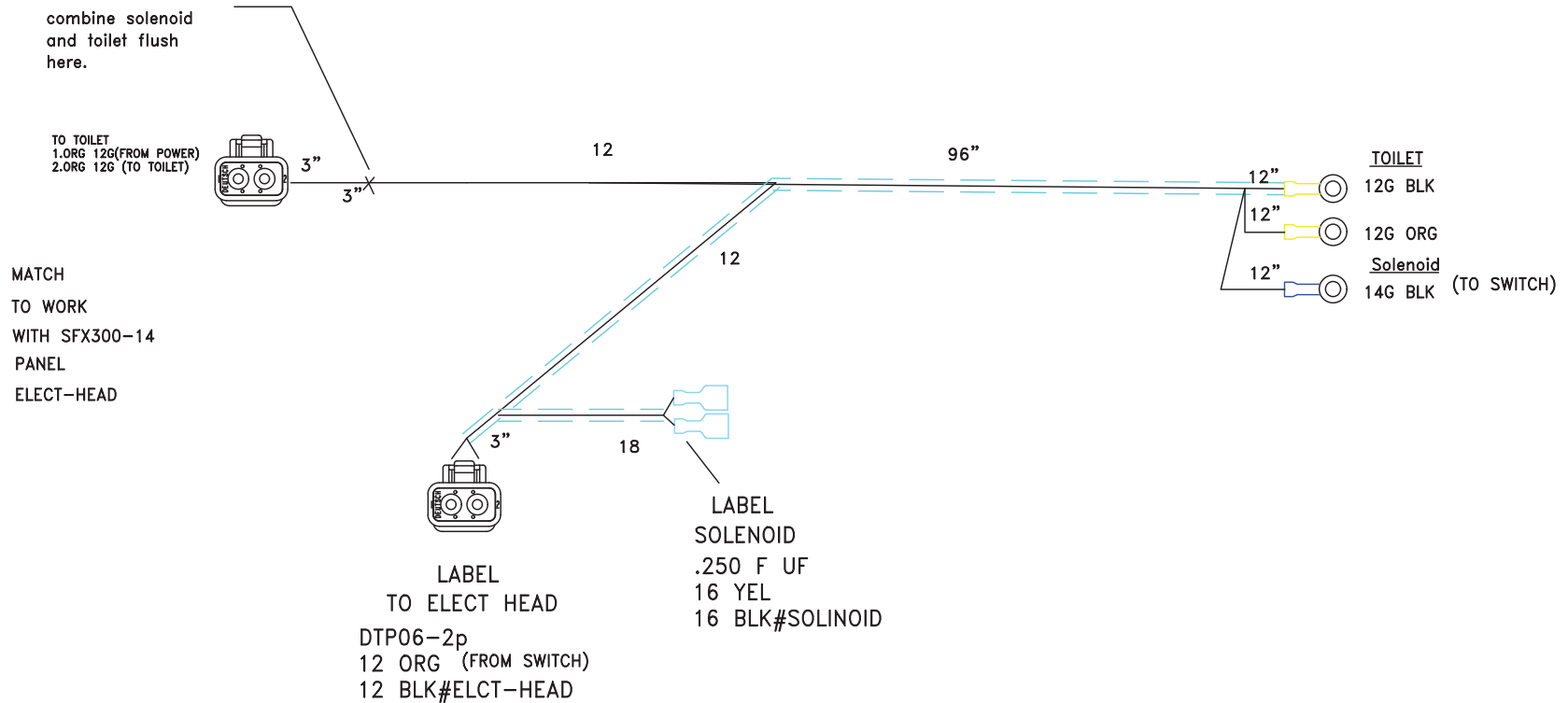

BATTERY WIRING

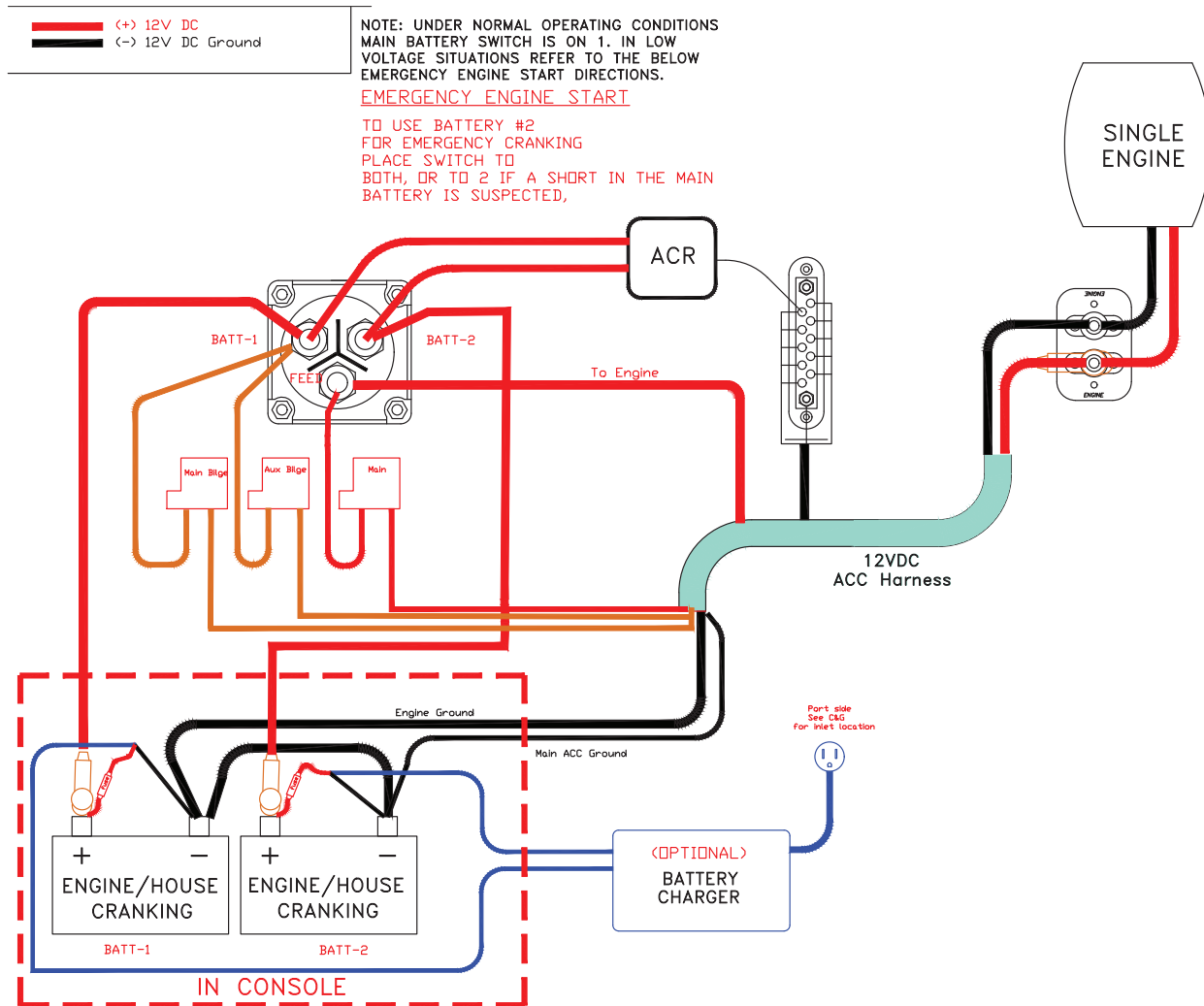

BATTERY WIRING

SEA FOX
BOAT WORKS

Sea Fox Boat Company, Inc.
2550 Highway 52
Moncks Corner, SC 29461-5024

Telephone: 843-761-6090
www.seafoxboats.com

Ken Cook Co.
Printed in U.S.A.
Rev 0325